

G4 Digital DC Input Modules

Features

- 4000 volts transient optical isolation
- Built-in LED status indicator
- Small footprint design, reducing mounting space by approximately 50 percent
- Built-in filtering for transient suppression and noise rejection
- Operating temperature: -30 °C to 70 °C
- UL recognized, CSA certified, CE approved
- Passes NEMA Showering Arc Test (ICS 2-230)
- Meets IEEE Surge Withstand Specification (IEEE-472)

Description

Opto 22's G4 DC input modules are used to detect on/off DC voltage levels. Each module provides up to 4000 volts (transient) of optical isolation between field inputs and the logic output of the circuit.

All DC input modules except the G4IDC5K and G4IDC5D are designed with filtering on the input and a hysteresis amplifier, providing high noise rejection and transient-free, "clean" switching. The G4IDC5K is a fast-switching module used to detect signals produced by photoelectric switches and TTL devices. The low-cost G4IDC5D is used for data acquisition.

The G4IDC5MA is a special module featuring a manual-on/manual-off/automatic switch, ideal for diagnostic testing of control applications.

The G4IDC5-SW and G4IDC5-SWNC modules supply power to an external dry contact switch and sense switch closure (SW) or opening (SWNC).

Typical applications for DC input modules include sensing the presence or absence of voltage and sensing contact closure from sources such as proximity switches, limit switches, selector switches, push buttons, photoelectric switches, and TTL-compatible devices.

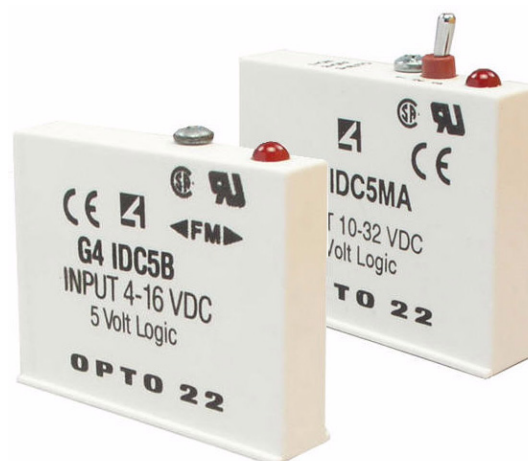

Opto 22 G4 digital input modules include the G4IDC5B high-speed module and the G4IDC5MA module with manual-on/manual-off/automatic switch for diagnostic testing.

Part Numbers

Part	Description
G4IDC5	G4 DC Input 10–32 VDC, 5 VDC Logic
G4IDC5B	G4 DC Input 4–16 VDC, 5 VDC Logic High Speed
G4IDC5D	G4 DC Input 2.5–28 VDC, 5 VDC Logic
G4IDC5G	G4 DC Input 35–60 VDC, 5 VDC Logic
G4IDC5K	G4 DC Input 2.5–16 VDC, 5 VDC Logic Very High Speed
G4IDC5MA	G4 DC Input 10–32 VDC, 5 VDC Logic With Manual/Auto Switch
G4IDC5-SW	G4 Switch Status Input, Self-powered, Normally Open
G4IDC5-SWNC	G4 Switch Status Input, Self-powered, Normally Closed
G4IDC15	G4 DC Input 10–32 VDC, 15 VDC Logic
G4IDC24	G4 DC Input 10–32 VDC, 24 VDC Logic

G4 Digital DC Input Modules

G4IDC5-SW and G4IDC5-SWNC Modules

Description

Each G4IDC5-SW and G4IDC5-SWNC module provides one isolated channel of contact status input. Each module supplies 13 volts of power to an external dry contact switch. The G4IDC5-SW senses switch closure; the G4IDC5-SWNC senses switch opening. Each user-supplied switch is connected with two wires. Because these modules include power for the switch, they are particularly cost-effective when labor costs for wiring external power are high.

Typical switches for use with these modules are switched status sensors (level sensors, pressure indicators, etc.), magnetic reed switches (used on doors or windows for burglar alarms), snap-action micro switches, the auxiliary switches on motor starters, and most relay contacts.

CAUTION: G4IDC5-SW and G4IDC5-SWNC inputs are not intended to be used with contacts that are connected to any external user-supplied voltage or currents.

Specifications

Field Side Ratings	
Open Circuit Voltage (Switch Open)	11 VDC min., 13 VDC typical, 15 VDC max.
Short Circuit Current (Switch Closed)	6 milliamps nominal
Minimum Off Resistance	≥20 K ohms
Maximum Allowable On Resistance (Wire + Contact Resistance)	500 ohms
Logic Side Ratings	
Logic Output Voltage for G4IDC5-SW (normally open)	<0.5 V max. (switch closed; LED on) @ 2 mA sinking 2.7 V min. (switch open; LED off) @ 0.4 mA sourcing
Logic Output Voltage for G4IDC5-SWNC (normally closed)	<0.5 V max. (switch open; LED on) @ 2 mA sinking 2.7 V min. (switch closed; LED off) @ 0.4 mA sourcing
Maximum Operating Common Mode Voltage (Field Term to Logic Connector)	250 V
Power Requirements:	5 VDC (±0.25) @ 25 mA nom.
Module Ratings	
Number of Channels Per Module	1
Turn-on Time	8 msec typical
Turn-off Time	8 msec typical
Input-to-output Isolation (transient)	4000 V AC/DC
Temperature	0 °C to 70 °C, operating -30 °C to 85 °C, storage

G4 Digital DC Input Modules

Dimensions

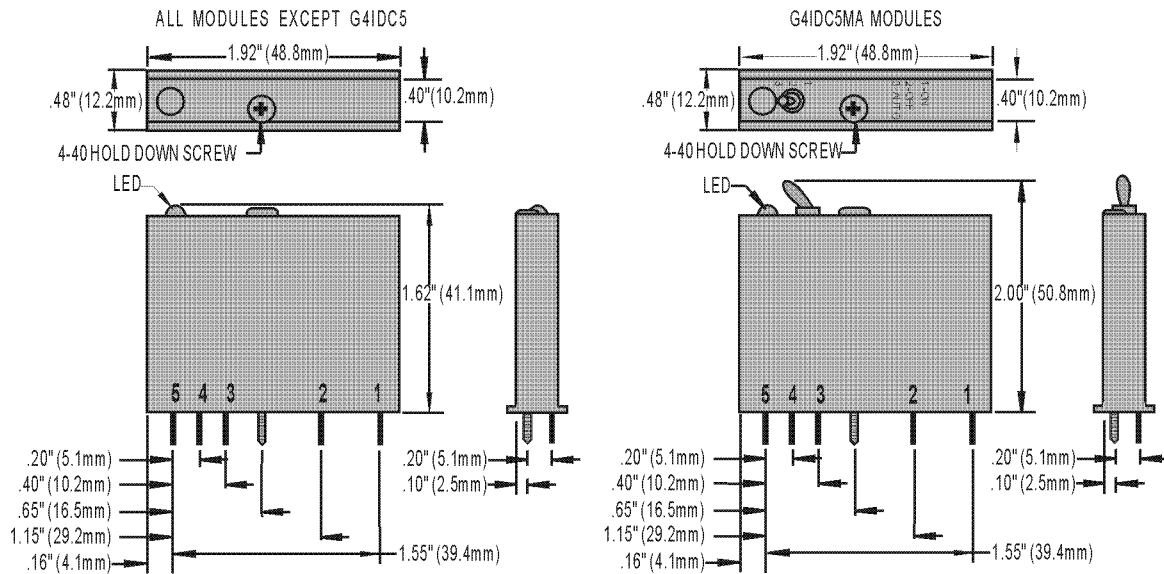

Schematics

